

Aluminium Frames

Aluminium Frames 60X60 Series

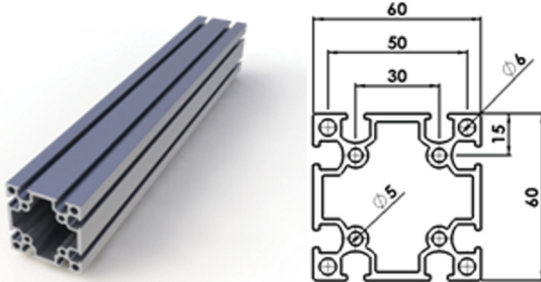

PARTICULARS		SURFACE TREATMENT :	
AREA :	9.629 CM ²	ANODICE PLATE	
WT :	2.619 KG/M	MATERIAL : 6063-T5	
PERIM :	43.908 CM	FACTOR : 9.822	
EXT PERIM :	CM	TOLERANCE :	

UNSPEC THICKNEES = MM, BREAK ALL SHARP CORNERS = 0.05 MM-R

Name	Profiles / Aluminium Frames
Item No.	SG1217-6060-4000

Length	4,000 mm.
---------------	------------------

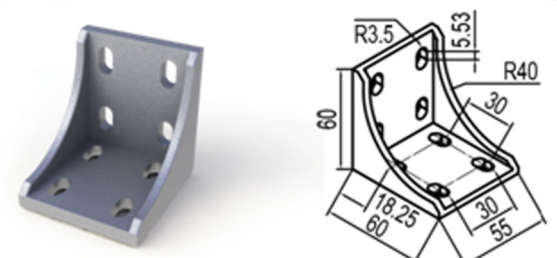

Name	Breaket
Item No.	DCB5560

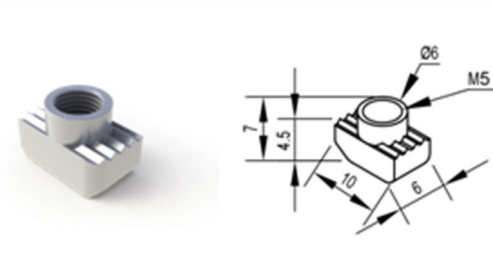

Name	T-NUT
Item No.	T6M5

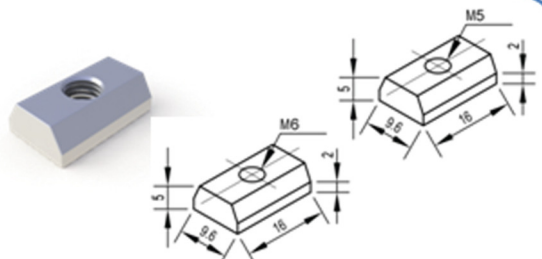

Name	S-NUT
Item No.	S6M5 , S6M6

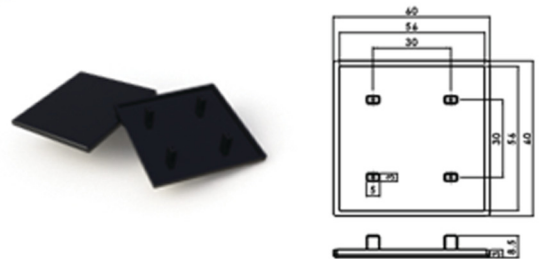

Name	End Cap
Item No.	DEC6060

